

# ***SUPERIOR***

**CONTAINER SOLUTIONS**

## **APARTMENT STYLE COMPACTORS**



The New Industry Leader  
For Waste Compaction Solutions.

# APARTMENT STYLE COMPACTORS

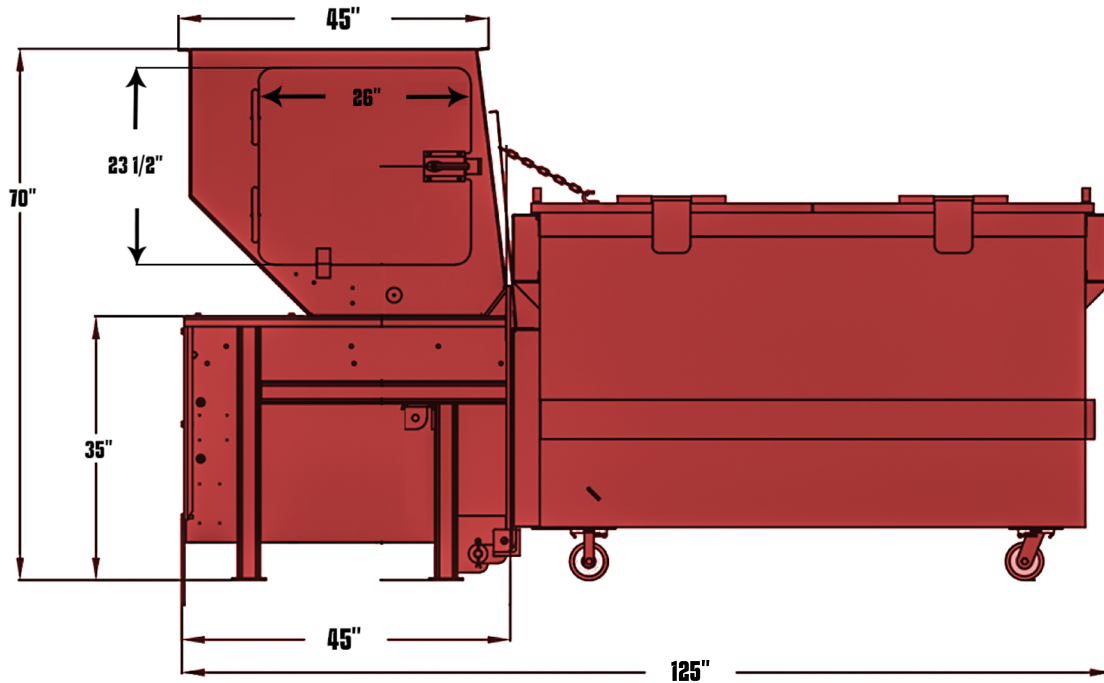

Dimensions & Specifications	
Performance Characteristics	
Electrical Equipment	
Hydraulic Equipment	



[superiorcontainersolutions.com](http://superiorcontainersolutions.com)

602-313-8075



# ***SUPERIOR*** **CONTAINER SOLUTIONS**

## **SELF CONTAINED COMPACTORS**



The New Industry Leader  
For Waste Compaction Solutions.



